

Reviews

Electrochemical Synthesis of Metal Oxides and Hydroxides

G. Helen Annal Therese and P. Vishnu Kamath*

Department of Chemistry, Central College, Bangalore University, Bangalore 560 001, India

Received July 16, 1999. Revised Manuscript Received January 3, 2000

Emerging electrosynthetic techniques such as electrogeneration of base, anodic oxidation, and ac (alternating current) synthesis provide simple and inexpensive alternative routes to the synthesis of ceramic thin films and coatings, nanoparticulate materials, and metastable phases. In this review, we survey illustrative examples to highlight the potential application of these techniques in meeting the goals of inorganic solid-state synthesis.

Contents

1. Introduction	1195
2. Electrochemical Synthesis: Features	1196
3. Designing an Electrochemical Synthesis	1196
4. Electrochemical Synthesis: Techniques	1197
5. Electrosynthesis of High Temperature Oxide Superconductors	1201
6. Electrosynthesis of Nanomaterials: Oxides, Oxysalts, and Composites	1202
7. Conclusions	1203

1. Introduction

The difficulties encountered during the synthesis of inorganic solids, on account of the limitations of diffusion in the solid state have been traditionally overcome (i) by reducing the particle size of the reactants or (ii) by eliminating the need for diffusion altogether by the use of solid solution or compound precursors.¹ These two strategies have led to the development of a plethora of low-temperature routes to the synthesis of inorganic solids which have been reviewed elsewhere.² A third strategy, which is applicable in the event of (i) the diffusing species being charged and (ii) the diffusion medium (more commonly called the host lattice) being porous, layered, or defective, is to induce diffusion by the application of an electric potential. This strategy can lead to the desired product even at room temperature. This technique, traditionally referred to as “electrosynthesis” has been included among the synthetic techniques available to the solid-state chemist in a number of reviews.³ The synthesis of Li_xMoS_2 ($0 < x < 1$)⁴ by the cathodic reductive intercalation of MoS_2 is an archetypical example of this approach, which has been over the years extended to other layered chalcogenides,

oxides, oxide-halides, hydroxides, chalcogenophosphates, and others.⁵ Despite its restricted application to the reversible intercalation of H^+ and Li^+ ions, this synthetic technique has yielded a large number of battery materials. We call this technique “the electromigration method” to distinguish it from other emerging electrosynthetic techniques, which form the subject of this review.

Two important developments have taken place over the last 10 years:

1. On the scientific front, the introduction of the principles of “chimie douce” (“soft chemistry”)⁶ has added a new dimension to solid-state synthesis with its emphasis on rational chemical–mechanistic based approach to and kinetic control over the reactions. While the earlier focus was on the synthesis of thermodynamically stable phases by low-temperature routes, the possibility of exercising kinetic control over solid-state transformations has given the chemist access to the world of metastable materials and the exciting properties and phenomena exhibited by them.⁷ The late Professor M. Figlarz who propounded the concept of metastability in the context of “chimie douce”, has classified it into different types.⁸ The three most relevant to the present discussion are (i) topological metastability of microporous and layered materials, (ii) structural metastability of epitaxial films, and (iii) morphological metastability of nanoparticulate materials.

The emphasis of inorganic solid-state chemistry has clearly shifted to the synthesis of metastable materials.

2. On the technological front, the challenge of developing oxide-based electronics⁹ has spawned a tremendous effort toward the fabrication of ceramic films ranging in thickness from the nanometer to the micrometer.

Currently, the established techniques of fabricating ceramic thin films include pulsed laser deposition, rf sputtering, electron beam etching, metal–organic chemi-

* Author for correspondence.

cal vapor deposition, and molecular beam epitaxy.¹⁰ Most of these techniques involve a two-step process. In the first step, the desired ceramic material is synthesized in bulk by any of the known conventional methods. In the second step, a pressed pellet of the ceramic is made a target for irradiation by a high-power laser, ion/electron beam, or a rf source. The resultant plume is captured onto a cold substrate. These techniques require a high power source and/or an ultrahigh vacuum system, making them extremely capital and energy intensive. Besides, there are instances where the film composition varies significantly from the target composition due to the different sputtering speeds of the target constituents. These techniques are also not suited to obtaining conformal coatings on curved substrates. Further, these techniques are inapplicable when the target material is a low-temperature phase, as irradiation would lead to instantaneous decomposition of the target material.

There is therefore an urgent need to develop simple and inexpensive chemical approaches to the fabrication of ceramic films on a variety of substrates.

2. Electrochemical Synthesis: Features

An electrochemical synthesis is achieved by passing an electric current between two or more electrodes separated by an electrolyte. By definition, the synthesis takes place at the electrode–electrolyte interface. We list below several features which distinguish electrosynthesis from other synthetic methods:

(i) Electrochemical synthesis takes place close to the electrode within the electric double layer, which has a very high potential gradient of 10^5 V cm^{-1} . Under these conditions, the reactions often lead to products which cannot be obtained in a chemical synthesis.

(ii) The product is deposited on the electrode in the form of a thin film or a coating. Further, a solid–liquid interface facilitates the growth of conformal coatings on substrates of any shape, especially if a suitably shaped counter electrode is employed to provide uniform polarization.

(iii) Electrochemical synthesis is a low-temperature technique limited by the boiling point of the electrolyte. This can be raised by using molten salt electrolytes.

(iv) Kinetic control can be exercised by controlling the current passed through the cell, while thermodynamic control can be exercised by choosing the applied cell potential.

(v) An electrochemical synthesis is an oxidation or a reduction reaction. By fine-tuning the applied cell potential, the oxidizing or reducing power can be continuously varied and suitably selected—a luxury not afforded by chemical synthesis.

(vi) The film composition can be controlled by varying the bath composition.

(vii) The experiments are simple to perform and the instruments are inexpensive and readily available.

There are, however, some disadvantages. Being an ambient temperature technique electrosynthesis often leads to poorly ordered products making unequivocal structural characterization difficult. Often, the product comes with X-ray amorphous impurities. Further electrodeposition can only be carried out on conducting substrates.

Nevertheless, the unique features of electrosynthesis eminently qualify it to join the ranks of “chimie douce” techniques and offer solutions to the twin challenges of making metastable phases and growing ceramic thin films.

3. Designing an Electrochemical Synthesis

The success of an electrosynthetic reaction depends on the proper choice of a number of reaction parameters:

- (1) Choice of an electrode— inert or reactive
- (2) Choice of an electrolyte
- (3) Choice of temperature, pH, concentration, and composition of the electrolyte solution
- (4) Choice of the cell—divided or undivided
- (5) Mode of electrolysis—potentiostatic or galvanostatic.

In a typical electrosynthesis, the reactant, which is dissolved in the electrolyte is deposited as a solid product. Consequently, the activity of the reactant decreases as the reaction proceeds. The two important parameters that determine the course of the reaction are (i) the deposition current and (ii) the cell potential. Of the two, any one can be controlled as a function of time during the reaction.

In a galvanostatic synthesis (see Figure 1a), a delicate control can be exercised over the rate of the reaction leading to deposits with good adhesion and a controlled morphology. However the cell potential drifts as the reactant activity decreases. The drift in the cell potential may lead to a multiplicity of products. A potentiostatic synthesis is carried out with a three-electrode assembly (see Figure 1b) by polarizing the electrode to a desired potential with respect to a reference electrode. In this case, the cell current usually decays rapidly as the reaction proceeds, both due to low rates of diffusion of the reactant molecules from the bulk to the electrode surface as well as due to decrease in activity of the reactant. However, the reaction is likely to yield a pure single-phase product selected for by the applied potential.

In a potentiostatic synthesis, the potential to be employed is not always known beforehand. Therefore, a linear voltammetry is first carried out by ramping the cell potential from an initial value, E_i , to a final value E_f (see Figure 1c). E_i and E_f correspond to potentials at which the solvent undergoes electrolysis, for instance, the hydrogen evolution and oxygen evolution potentials for an aqueous electrolyte solution. A potentiostatic synthesis can be carried out if the reaction takes place at any potential intermediate between these two values. If the reaction potential falls outside the window provided by E_i and E_f , then a suitable electrode and solvent have to be chosen with the appropriate potential window which includes the reaction potential. A divided cell helps to separate the product of the cathodic reaction from that of the anodic reaction and the chemical composition of the product is controlled by varying the electrolyte composition.

In an actual synthesis, one or more of these synthetic parameters may have to be empirically selected by performing a large number of trials, keeping in view the product quality.

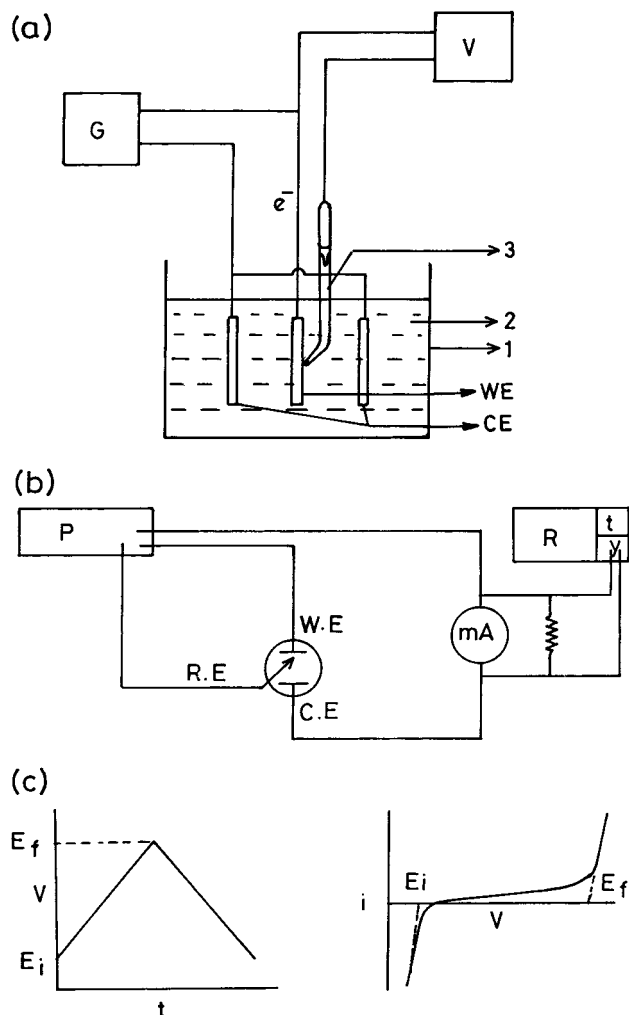

Figure 1. A schematic representation of galvanostatic (a) and potentiostatic (b) synthesis. The applied potential and the current response of an electrochemical cell under a potentiodynamic operation (c): G, galvanostat; V, voltmeter; P, potentiostat; R, recorder; RE, reference electrode; WE, working electrode; CE, counter electrode; 1, electrochemical cell; 2, electrolyte; 3, Lugin capillary.

4. Electrochemical Synthesis: Techniques

In Table 1, we list the various techniques of electrosynthesis and the nature of products obtained from each. Of these, the first two are well-known and reviewed elsewhere. The first, viz. synthesis by electromigration,¹¹ is a typical "chimie douce" technique, highlighting kinetic control over the reaction by electrochemistry. This technique involves intercalation (or deintercalation) of a guest ion in a host lattice by applying an electric potential between the working and counter electrodes, where the host material (working electrode) is prepared by a conventional high-temperature route. In the second technique, i.e., electrolysis of fused salts,¹² a low-melting salt with flux, containing the transition metal oxide, is melted and electrolyzed at elevated temperatures using an inert Pt electrode or a reactive metal electrode such as Fe, Co, or Ni depending on the desired product. Cathodic reduction or anodic oxidation leads to single crystals of the product which can be recovered by washing away the electrolyte. Single

crystals of FeV_2O_4 , WS_2 , Fe_2P , and TiS_2 have been prepared by this technique. However there is no clear understanding of the mechanism and the synthetic conditions appear to be chosen empirically.

In this review, we focus on the remaining three techniques, which have been developed in the last 10 years or so. Finally we examine how these techniques have been employed for the synthesis of two classes of speciality materials viz. the high-temperature superconducting oxides and nanoparticulate oxide materials.

4.1. Electrogeneration of Base. It is well-known that when electric current is passed through a metal-salt solution, the metal is deposited at the cathode. This principle is widely used by plating technologists to obtain metal coatings. But depending upon the deposition potential, choice of the anion and the pH of the solution various other reactions take place at the cathode.¹³ They include

(1) Reactions which consume H^+ ions such as

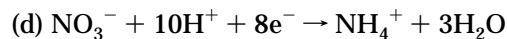
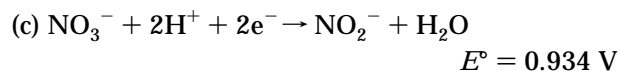
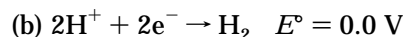
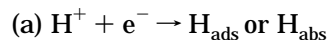

(2) Electrolysis of water

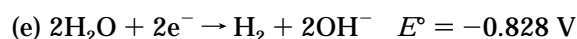

(3) Anion (for example, nitrate) reduction reactions

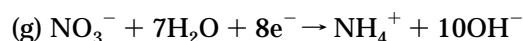
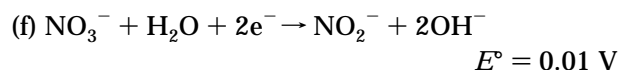

All these reduction reactions cause an increase in the pH of the electrolyte, close to the electrode either by the consumption of H^+ ions or by the generation of OH^- ions. They effectively compete with the metal ion reduction reaction

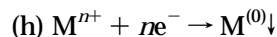

On purely thermodynamic considerations, the reaction with the most positive E° value would be preferred over the others. Reactions of the type (f) and (g) have a more positive E° value compared to most metal ion reduction reactions¹⁴ (except for those of Cu^{2+} , Ag^+ , and Bi^{3+}). As a result metal deposition does not take place in most nitrate baths. On the other hand, the metal ion deposits in the form of a hydroxide on the cathode as



The best known application of this technique is the synthesis of nickel hydroxide by the electroreduction of aqueous nickel nitrate solutions.¹⁵ Under certain conditions the metastable α -modification of nickel hydroxide is electrodeposited in preference to the thermodynamically stable β -modification. This reaction is widely employed for the fabrication of nickel hydroxide-based

Table 1. Summary of the Electrosynthetic Techniques Employed in Inorganic Solid-State Chemistry

technique	product	application
1. electromigration of reactant species	polycrystalline powders/ single crystals	battery electrode materials
2. electrolysis of fused salts	single crystals	crystal growth at moderate temperature
3. electrogeneration of base by cathodic reduction	coatings/films/powders	synthesis of electrode materials for secondary cells, fabrication of hydroxide films/coatings
4. anodic oxidation	coatings/films/powders	synthesis of compounds with high oxidation state
5. alternate current synthesis	layer-by-layer films/coatings	synthesis of composites/solid solutions

cathodes for Ni–Cd, Ni–Fe, Ni–Zn, and Ni–MH (metal hydride) batteries.

The relative importance of these three classes of reactions in electrogeneration of base is not known. All mechanistic investigations carried out in this regard employ nitrate baths, implicitly assuming the overwhelming role of nitrate reduction in electrogeneration of base. But our own studies¹⁶ on the electrosynthesis of Mg(OH)₂ as a model reaction have shown that the yield of Mg(OH)₂ is much higher from a Mg–chloride bath when compared to a Mg–nitrate bath under all deposition conditions. Since the chloride ion does not participate in any anion reduction reactions, hydrogen evolution reactions (HER) are the only ones responsible for electrogeneration of base in a chloride bath. It appears that HER is as important as nitrate reduction in the electrosynthesis of hydroxides. Extending this technique, α-nickel hydroxide has been electrosynthesized from chloride and sulfate baths¹⁷ with comparable yields as from a nitrate bath.

4.1.1. Synthesis of Hydroxides. A number of unary hydroxides of s-block (Mg²⁺), p-block (Al³⁺), and d-block (Cr³⁺, Mn³⁺, Fe³⁺ and Co²⁺) metals¹⁸ have been synthesized by cathodic reduction. However, electroreduction of the salts of Cu, Tl, Bi, and Pb yielded only metal deposits.

In an effort to electrodeposit the hydroxides of Cu, Tl, Bi, and Pb, all of which are promising precursors to superconducting oxides, the cathodic reduction technique was extended to perchlorate baths.¹⁸ The perchlorate reduction reactions have much higher E° values than the nitrate reduction reactions:

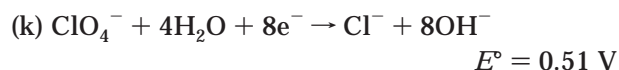
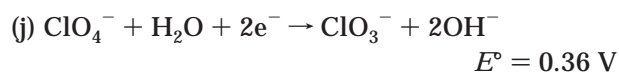

These values compare very favorably with the E° values of metal ion reduction reactions of Cu²⁺ (0.345 V), Tl⁺ (–0.338 V), Bi³⁺ (0.226 V), and Pb²⁺ (–0.126 V). It was therefore expected that perchlorate reduction should yield their respective hydroxides. However these experiments¹⁸ failed to yield hydroxide deposits in the case of these metals, showing that E° value is not the sole determining criterion for the success of this class of electrosynthetic reactions. Other unknown kinetic factors also play a crucial role.

For technological applications, the electrosynthesized coating should be crack-free, have a high adhesion strength and form an ohmic contact with the substrate. We have observed that reactive electrodes such as Ni and stainless steel yield coatings with superior mechan-

ical properties compared to inert electrode substrates such as Pt. Aries and co-workers¹⁹ have studied the electrodeposition of Al(OH)₃ on stainless steel substrates to investigate the role of interfacial compounds in the bonding of the hydroxide coating to the substrate. Under the superficial layer of Al–oxide/hydroxide is found a layer of Fe(Cr,Al)₂O₄ oxide of the spinel structure with a compositional gradient. Compositionally graded interfacial oxide layers play a crucial role in providing adhesion. The substrate electrode is often subjected to electrochemical and/or chemical treatment to produce an appropriate surface layer conducive to the adhesion of the coating.

Coprecipitation of trivalent metal ions along with divalent hydroxides leads to the formation of a class of compounds called the layered double hydroxides (LDHs), which have the general formula M^{II}_{1–x}M^{III}_x(OH)₂A^{n–}_{x/n}yH₂O (M^{II} = Mg, Co, Ni, Cu, Zn; M^{III} = Al, V, Cr, Mn, Fe, Ga; A = Anion; y = 0.5–1).²⁰ The LDHs consist of a stacking of positively charged layers of the composition [M^{II}_{1–x}M^{III}_x(OH)₂]^{x+}, which then intercalate anions and water molecules in the interlayer region for the purposes of charge neutrality and stability. The LDHs find application as sensors, catalysts, anion-exchange resins, and sorbents, and as electrodes for alkaline secondary batteries.²¹ For many of these applications, they are needed in the form of thin films and coatings. We have electrosynthesized the LDHs of Ni and Co with Al³⁺, Cr³⁺, Mn³⁺, and Fe³⁺ on Pt foil electrodes for electrochemical applications.²² The LDH of Mg with Al, the synthetic analogue of the archetypical mineral LDH, the hydrotalcite, has been electrochemically synthesized on a Pt electrode.

4.1.2. Synthesis of Oxides. Switzer²³ introduced this technique for the first time as a synthetic route to oriented ceramic films as well as polycrystalline powders. Polycrystalline CeO₂ powder was synthesized from a cerous nitrate solution, although the mechanism was not well understood at that time. Further studies²⁴ from his group have shown that the electrosynthesized CeO₂ is nanocrystalline, and sinters at a much lower temperature (750 °C) than CeO₂ synthesized by other conventional techniques and yield dense powders. A recent study by Feng-Bin Li and co-workers²⁵ gives the chemical mechanism of the formation of CeO₂. According to them, CeO₂ forms due to oxidation of Ce(III) to Ce(IV) by hydrogen peroxide, which is formed due to dissolved oxygen reduction in the electrolyte as

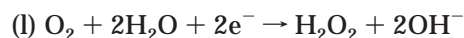

The overall reaction is given as

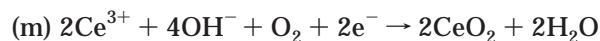

The oxygen reduction reaction (ORR) also appears to be an important source of electrogenerated base.

The electrochemical synthesis of precursors to polycrystalline powders of ZrO_2 ,²⁶ TiO_2 ,²⁷ and ZrTiO_4 ²⁸ and coatings of ZrO_2 ,²⁹ Al_2O_3 ,^{29,30} $\text{Al}_2\text{O}_3\text{-ZrO}_2$,³¹ and $\text{Al}_2\text{O}_3\text{-Cr}_2\text{O}_3$ ³² has been reported by different groups, most notably by that of Gal-Or from Israel. These syntheses have been achieved by the galvanostatic reduction of the respective mixed-metal nitrate/chloride solutions in the presence of hydrogen peroxide at various current densities ranging from 10 to 100 mA cm^{-2} . Graphite or Ti working electrodes were used. In these syntheses the OH^- ions generated, result in the formation of colloidal particles of the hydrolyzed compounds of Zr or Ti on the cathode which on heat treatment yield the respective metal oxides. This method is very useful in the preparation of fine powders and adherent coatings.

Similarly, precursors for oxides such as PbO_2 ,³³ Cr_2O_3 ,³⁴ Nb_2O_5 ,³⁵ ZnO ,³⁶ and WO_3 ³⁷ have been prepared by electrogeneration of base. In all these syntheses, the oxides can be obtained as adherent coatings, a few micrometers thick, by adjusting certain parameters such as electrolyte concentration, current density, deposition time, electrolyte pH, and temperature.

Among the ternary oxides, those of the perovskite structure show a wide variety of electrical and magnetic properties. Typical examples are the dielectric oxides BaTiO_3 ³⁸ and lead zirconate titanate,³⁹ thin films of which have been prepared by cathodic reduction. Konno and co-workers⁴⁰ have made thin films of $\text{La}_{1-x}\text{M}_x\text{CrO}_3$ ($\text{M} = \text{Ca}, \text{Sr}$) by heat treatment (700 °C, 10 min) of the hydroxy-chromate precursor obtained by cathodic reduction of a mixed-metal nitrate solution containing $(\text{NH}_4)_2\text{Cr}_2\text{O}_7$. Films of LaFeO_3 have been prepared by Hombo and co-workers⁴¹ by heat treatment of an electrogenerated hydroxide precursor at 700 °C which is much lower than the temperature (>1000 °C) used in the conventional ceramic preparation. We have electrogenerated highly crystalline rare-earth chromates of the formula $\text{Ln}_2\text{Cr}_3\text{O}_{12}\cdot 7\text{H}_2\text{O}$ ($\text{Ln} = \text{La}, \text{Pr}, \text{Nd}$) by cathodic reduction of a $\text{Ln}(\text{NO}_3)_3$ solution containing $\text{K}_2\text{-Cr}_2\text{O}_7$ both as adherent coatings and polycrystalline powders.⁴² These coatings on heat treatment (750 °C, 10 min) yielded very adherent LnCrO_3 coatings. The limiting thickness of the coating was estimated to be 51 μm from density data. Similarly LaMnO_3 coatings of thickness ranging from 0.5 to 2.6 μm have been synthesized by cathodic reduction.⁴³ LaMnO_3 coatings are of importance as they exhibit the property of giant magnetoresistance (GMR). Ferromagnetic coatings of $\text{La}_{1-x}\text{Ca}_x\text{MnO}_{3+\delta}$ ⁴⁴ have also been prepared by cathodic reduction of nonaqueous solutions and found to exhibit GMR behavior.

4.1.3. Synthesis of Metal Phosphates. During the course of our work on this technique we have electrogenerated a number of metal phosphates. Of special interest is the calcium hydroxyapatite $[\text{Ca}_5(\text{OH})(\text{PO}_4)_3]$ which is crystallographically similar in structure to various calcified tissues of vertebrates. It is therefore used as a biocompatible coating on metal endoprostheses. Conventionally this coating is fabricated by pulsed laser deposition on account of which the metal implants are expensive. We have fabricated $\text{Ca}_5(\text{OH})(\text{PO}_4)_3$ coatings from an aqueous bath containing $\text{Ca}(\text{NO}_3)_2$ and

Table 2. Oxides Synthesized by Electrogeneration of Base by Cathodic Reduction

compound	technique ^a	applications	ref(s)
CeO_2	P and G	gas sensor, fuelcells	23–25
$\text{La}_{1-x}\text{M}_x\text{CrO}_3$ ($\text{M} = \text{Ca}, \text{Sr}$ or Ba)	P	electronic conductor	40
PbO_2	G	electrode material	33
ZrO_2	G	ionic conductor	26, 29
BaTiO_3	P	dielectric components	13, 38
LaFeO_3	P and G	oxide coating	41
PZT	P and G	dielectric and piezoelectric components	39
Al_2O_3	P	corrosion-protective coating	19, 29
Cr_2O_3	G	wear and corrosion-resistant coating at high temperatures	34
$\text{Mo}_{1-x}\text{M}_x\text{O}_3$ ($\text{M} = \text{Co}, \text{Cr}, \text{Ni}, \text{W}$ or Zn)	G	optical light modulators	47
ZrTiO_4	G	industrial application	28
TiO_2	P	photocatalyst	26c, 27
Nb_2O_5	P	ceramic oxide film	35
Nd_2CuO_4	G	superconductor	48
ZnO	P	optical and electronic devices	36
$\text{Ln}_2\text{Cr}_3\text{O}_{12}\cdot 7\text{H}_2\text{O}$	P and G	corrosion-protective coatings	42
LaMnO_3	G	GMR	44
$\text{Ni}(\text{OH})_2$	G	electrode material	15, 49
hydroxyapatite	G	biocompatible coating	45, 46
WO_3	G	electrochromic devices	37
$\text{Al}_2\text{O}_3\text{-M}$ oxides	G	composites	29, 31, 32

^a Abbreviations: P, potentiostatic; G, galvanostatic

diammonium hydrogen phosphate at pH 2.2.⁴⁵ The coating growth characteristics are convenient to achieve rapid (0.5–1 h) synthesis of micrometer thick coatings on stainless steel substrates with good adhesion. Calcium hydroxyapatite coatings were also prepared at potentials ranging from -1.3 to -1.5 V from an electrolyte containing $\text{Ca}_{10}(\text{PO}_4)_6(\text{OH})_2$ dissolved in 1 M NaCl solution at pH 4.4.⁴⁶ In Table 2 we list the significant solid-state syntheses achieved by the cathodic electrogeneration of base technique.

4.2. Anodic Oxidation. In this technique, a metal ion in a lower oxidation state is oxidized to a higher oxidation state anodically. The pH of the electrolyte is chosen in such a way that the lower oxidation state is stable while the higher oxidation state readily undergoes hydrolysis to yield the metal oxide or hydroxide.

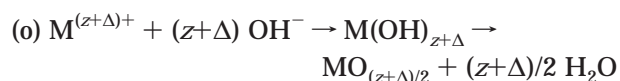

This technique also inspires battery technologists, who fabricate PbO_2 and MnO_2 electrodes by the anodic oxidation of solutions containing Pb^{2+} and Mn^{2+} ions, in keeping with the scheme above.^{50,51} Electrosynthesis leads to the formation of defect PbO_2 and $\gamma\text{-MnO}_2$ (also called electrolytic manganese dioxide, EMD) respec-

tively, both metastable forms which exhibit a higher electrochemical activity compared to other polymorphic modifications obtained by chemical synthesis.

Switzer⁵² deposited Ti_2O_3 films of 3 μm thickness on a titanium electrode by anodic oxidation of an alkaline Ti(II) acetate solution. At moderate current densities of 1–10 mA/cm^2 the Coulombic efficiency for galvanostatic deposition was shown to be nearly 100%. A photovoltaic efficiency of up to 13.8% was achieved for Ti_2O_3 deposited on a n-Si substrate.

Co-workers in this laboratory have co-deposited MnO_2 with PbO_2 and Ti_2O_3 in an effort to improve the electrode performance of MnO_2 .⁵³ Cyclic voltammetric studies on composite films (MnO_2 – PbO_2 , MnO_2 – Ti_2O_3 , and MnO_2 – PbO_2 – Ti_2O_3) show that the cycle life of MnO_2 is improved from 5 cycles to 10 and the reversibility measured by the ratio of cathodic to anodic peak currents increases from 0.64 to 0.86 in the MnO_2 – PbO_2 composites where as Ti_2O_3 is deleterious to the reversibility of the electrode.

The research on anodic oxidation of Ti(II) to Ti_2O_3 and Pb(II) to PbO_2 by Sasaki and co-workers⁵⁴ resulted in a new compound $\text{Pb}_8\text{Ti}_5\text{O}_{24}$ with a cubic fluorite structure. $\text{Pb}_8\text{Ti}_5\text{O}_{24}$ was electrodeposited on a platinum plate from an alkaline mixed-metal bath potentiostatically.

MnO_2 -based organic–inorganic composites can also be deposited by this technique. Kuwabata and co-workers⁵⁵ have made composite films of MnO_2 and polypyrrole under optimized conditions for application as cathode materials for rechargeable lithium secondary batteries. Specific energy densities of such electrodes improved from 266 C cm^{-3} for pure polypyrrole to 400 C cm^{-3} for the MnO_2 -containing composite electrodes.

Tench and Warren⁵⁶ extended this scheme of synthesis for the first time to other systems and prepared thin films of the oxyhydroxides of trivalent Ni, Co, Fe, and Mn by the anodic oxidation of the respective divalent ions dissolved in an acetate buffer of pH 6. The NiO(OH) exhibits a reversible charge storage redox chemistry and electrochromism. MnO(OH) and CoO(OH) are highly electrically conducting. V_2O_5 has been deposited on various substrates such as stainless steel, platinum, nickel, glassy carbon, graphite, woven carbon cloth, and SnO_2 glass by anodic oxidation of a saturated aqueous NH_4VO_3 solution by both galvanostatic and potentiostatic techniques.⁵⁷ Best deposits were obtained for bath temperatures in the range of 40–60 °C. Studies on the insertion of H^+ and Li^+ into these electrodes resulted in three phases of $\text{Li}_x\text{V}_2\text{O}_5$ with various values of x . These materials have potential applications as electrodes for lithium batteries.

There are other anodic syntheses where the electrode itself acts as a source for compound formation by undergoing dissolution (or oxidation) during synthesis. Examples of such syntheses are BaWO_4 ,⁵⁸ SrWO_4 ,⁵⁹ and $\text{Sr}_{1-x}\text{Ca}_x\text{MoO}_4$ ⁶⁰ which have been electro synthesized using W (or Mo) electrodes from the respective alkaline-earth metal hydroxide solutions galvanostatically. These compounds are luminescent materials. Mechanistic studies have revealed the following pathway:

(i) WO_4^{2-} species form on the anode in an alkaline solution



(ii) these WO_4^{2-} species react with M^{2+} (Sr^{2+} or Ba^{2+}) ions in the solution to form MWO_4



This method gives very well ordered defect-free crystals at room temperature. This technique has advantages over ceramic syntheses of SrWO_4 powders which always contain impurity phases.

Matsumoto and co-workers⁶¹ have made important contributions toward the anodic electro synthesis of perovskite oxides LnMO_3 (Ln = rare earth; M = Mn, Co, Ni). Their studies have shown that even though Ln^{3+} ions do not participate in any oxidation reactions, they can be incorporated into anodically grown oxyhydroxide films of Mn and Co provided a high Ln^{3+}/M ratio (100–1000) is maintained in the electrolyte. These precursor films on heat treatment yield LaMnO_3 and LaCoO_3 coatings. These compounds find wide application as electrode materials for solid oxide fuel cells (SOFCs). A similar synthesis incorporating La^{3+} in the NiO(OH) deposit led to the Ruddleson–Popper phase $\text{Li}_4\text{Ni}_3\text{O}_{10}$.⁶² All these syntheses have been carried out potentiostatically and the deposition conditions have been determined empirically by performing a large number of experiments. For instance, potential measurements studied during the deposition of the film from cobalt acetate, cobalt sulfate, and cobalt nitrate show that a single-phase LaCoO_3 can be obtained only at 0.95 V in the case of $\text{Co(CH}_3\text{COO)}_2$ solution and in the potential region 0.70 to 0.95 V for CoSO_4 and $\text{Co(NO}_3)_2$ solutions. These correspond to the formation of Co_2O_3 where cobalt exists in Co^{3+} state and the potential region above this value corresponds to the formation of CoO_2 where cobalt exists in Co^{4+} state. The precursor in this instance has been identified to be $[\text{Co}_2\text{O}_3 \cdot 2\text{La(NO}_3)_3 \cdot 3\text{H}_2\text{O}]$, which on heat treatment at 500 °C yields a LaCoO_3 coating.

The anodic oxidation technique is especially suited for the synthesis of compounds with metal ions in unusual high oxidation states. An example is the stabilization of Fe(IV) , Co(IV) , Ni(IV) , or Cu(III) which can be achieved only partially in complex ternary oxide systems by conventional ceramic techniques. Hansen and co-workers⁶³ have synthesized LDHs of Co with Fe and anodically oxidized them to obtain hexagonal layered oxides of the type $\text{Co}_{1-x}\text{Fe}_x\text{O}_2\text{H}_z$ ($z < 0.4$) where both Co and Fe are stabilized in the higher oxidation state of +4. The reaction was carried out at the ambient temperature potentiostatically at 1.3 V versus SCE for 1 h.

In Table 3 we list important anodic syntheses reported in the literature.

4.3. Alternating Current Synthesis: From Layer-by-Layer Composites to Solid Solutions. It is evident from the preceding sections that some materials such as nickel hydroxide are deposited by cathodic reduction, while others such as MnO_2 are deposited by anodic oxidation. Our search for improved battery

Table 3. Oxides Synthesized by Anodic Oxidation

compound	technique ^a	application	ref(s)
Ni(OH) ₂ /NiOOH, CoO ₂ , FeO, and MnO ₂	P	electrode material	56
Pb ₈ Tl ₅ O ₂₄	P	oxide coating	54
NiO(OH), Co ₂ O ₃	P and G	alkaline water electrolysis	64
thallic oxide	G	heterojunction solar cells	52
hydrated V ₂ O ₅	G	ion-selective electrode	57
Fe _{3-x} Li _x O ₄	G	magnetic devices, electrode material	65
LaCoO ₃	P and G	oxidation and electrocatalyst	61d
WO ₃ with Co, Cr, Fe, Mo, Ni, Ru, and Zn	G	electrochromic devices	66
TiO ₂	P	photocatalyst	67
nickel oxides	G	electrode material	68
AgO	G	battery material	69

^a Abbreviations: P, potentiostatic; G, galvanostatic

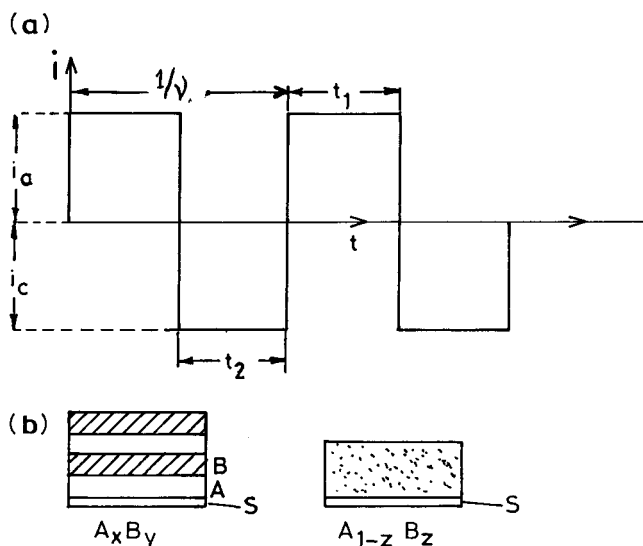

Figure 2. A square wave ac showing the possible variables. Schematic representation of a layer by layer composite (a) compared with that of a solid solution (b): S, substrate electrode.

materials necessitated the simultaneous deposition of the two.⁷⁰ In principle, this can be achieved by the pulsed electrolysis of a mixed metal nitrate bath containing both Ni²⁺ and Mn²⁺, by the use of alternating current. The preferred waveform is a square wave (see Figure 1.2a).

During pulsed electrolysis, the working electrode is alternately polarized anodically for a length of time, t_1 (called the on-time) and then cathodically for time, t_2 (called the off-time). The anodic (i_a) and cathodic (i_c) currents or potentials (V_a and V_c) can be varied, as can the amplitude ($i_a + i_c$) or ($V_a + V_c$). $i_a t_1$, determines the thickness of the anodic deposit (say A), while $i_c t_2$ determines the thickness of the cathodic deposit (say B). Large values of t_1 and t_2 (low frequencies) would lead to layer-by-layer composites of the type $A_x B_y$, whereas small values (high frequencies) can in principle lead to a single-phase solid solution of the type $A_{1-z} B_z$ (see Figure 2b), where x , y , and z are determined both by the bath composition and the Coulombic efficiencies of the anodic and cathodic reactions. Although such syn-

theses are conceptually feasible, to the best of our knowledge, Switzer and co-workers,⁷¹ are the only group to have utilized the full flexibility of this technique for rational synthesis.

Voltage as well as current pulses ("galvanostatic pulsing") were used to obtain oxide films in the Pb-Tl system using a stainless steel electrode and a mixed Pb(II)-Tl(I) bath. At low current densities, the films were Tl-rich while at high current densities the films were Pb-rich. Using a pulsed anodic current, Switzer and co-workers⁷¹ synthesized compositionally modulated (Tl_a-Pb_bO_c/Tl_dPb_eO_f) thin film superlattices. Switzer has suggested that such compositionally modulated layers can be synthesized only if (1) the materials are isomorphous (2) they can be deposited as anhydrous oxides and (3) their composition can be varied by varying the applied potential or current. There are very few systems that satisfy these conditions explaining the paucity of synthetic work in this area.

5. Electrosynthesis of High-Temperature Oxide Superconductors

The simplicity of electrosynthesis has prompted the widespread application of these techniques to the synthesis of oxide superconductors. Different techniques have been employed.

5.1. Control of Oxygen Content by Electrochemical Oxidation/Reduction. The superconducting property is critically dependent on the oxygen content of the oxide. Conventionally, the oxygen content is controlled by high-temperature annealing of the parent oxide in an oxygen atmosphere. The annealing conditions (temperature, duration, and oxygen pressure) are optimized by laborious systematic experimentation. Electrochemical oxidation combined with coulometry is a simple ambient temperature alternative to control the oxygen content of an oxide. This technique has been demonstrated most successfully in the La₂CuO₄ system. In a typical study, the parent semiconducting La₂CuO_{4.0} phase is obtained by a ceramic preparation. A pressed pellet of this oxide is then polarized anodically (potentiostatic mode) in a mild acidic⁷² or alkaline⁷³ electrolyte which may be aqueous⁷⁴ or nonaqueous.⁷⁵ Molten nitrate baths can also be used.⁷⁶ Bulk superconductivity is observed after this electrochemical treatment with remarkable consistency between oxidation state of Cu (measured iodometrically), excess oxygen (measured thermogravimetrically) and the coulometric data. Several possible mechanisms such as oxygenation (by the reaction of OH⁻ ions or H₂O) of the parent oxide and anodic dissolution leading to A site or B site cation-deficient oxides have been considered.

The electrochemical oxidation is a reversible process and the superconducting phase can be reduced back to the parent La₂CuO_{4.0} either by proton intercalation or by removal of excess oxygen.

Electrochemical control of the oxygen content in the YBa₂Cu₃O_{7-x} (123) system has been achieved by electroreduction of the sample to achieve an appropriate x value.⁷⁷ Electroreduction is facilitated by the enhanced diffusion of oxide ions under the influence of the applied potential in the 123 phase.

5.2. Molten Salt Electrolysis. A typical application of this technique is the synthesis of single crystals of

superconducting oxides at moderate temperatures (80–300 °C) in a single step. Further heat treatment of these crystals (400 °C) does not improve the T_c , but sharpens the transition temperature.

Single crystals of BaBiO₃-derived superconducting oxides are synthesized by anodic oxidation of molten salt mixtures containing Ba(OH)₂, KOH, and Bi₂O₃ at moderate temperatures (200 °C) by galvanostatic⁷⁸ or potentiostatic⁷⁹ method. Millimeter-sized crystallites with K doped in the A site with T_c in the range 15–30 K could be recovered. Magnetic susceptibility measurements show that single crystals doped with K are superconducting, whereas single crystals doped with Na are not, even though their structures are similar.

Tang and co-workers⁸⁰ extended this technique to the synthesis of La_{2-x}Na_xCuO₄ superconducting crystals. Experiments conducted at various current densities show that higher current densities do not yield a pure phase due to insufficient La³⁺ diffusion in the electrolyte, similarly high La/Cu ratios improve the quality of the product by reducing CuO formation. This compound shows a T_c of 30 K.

5.3. Potential Cycling of a Copper Foil. The ability of metals to form thin oxide films on potential cycling in a suitable electrolyte has been explored to grow superconducting thin films. Copper foils cycled in an aqueous barium hydroxide solution have been shown to incorporate Ba²⁺ ions in their oxide thin film.⁸¹ Potential cycling in a mixed-metal electrolyte comprising barium hydroxide–yttrium nitrate–copper acetate in mild acidic pH (6.5) led to the growth of thick and porous copper oxide films incorporating both Y and Ba. Oxygen annealing of the film resulted in the formation of a 123 related phase with a broad transition indicated by magnetization experiments.⁸²

5.4. Hydroxide Precursor Synthesis by Cathodic Reduction. Cathodic reduction of mixed-metal nitrates in aqueous,⁸³ or nonaqueous (containing trace water)⁸⁴ medium results in the formation of mixed hydroxides of the respective metals in the required ratio. The hydroxide precursor is heat treated at high temperatures to obtain the superconducting film.

YBa₂Cu₃O_{7-x} superconducting films were prepared by cathodic reduction of a mixed-metal nitrate solution containing Y, Ba, and Cu potentiostatically. Deposition potential and the bath composition determine the composition of the precursor. The superconducting films prepared by this technique show a T_c in the range of 79–88 K.

5.5. Alloy/Metal Deposition by Cathodic Reduction. Superconducting films of different oxide systems such as YBaCuO,^{85a} ErBaCuO,^{85b} TlBaCaCuO,^{85c,86} and BiSrCaCuO⁸⁷ have been synthesized by cathodic reduction of a mixture of metal nitrates in a nonaqueous (DMSO) bath. Cathodic reduction results in the formation of an alloy precursor film with metals in the required ratio. These films are heated at various temperatures in O₂ atmosphere to obtain the superconducting material.

Bartlett and co-workers⁸⁸ have synthesized a BiSrCaCu alloy precursor film at -3.25 V from a mixed-metal nitrate bath. The samples obtained after deposition were dried at 200 °C for 10 min and then annealed at 810 °C in air. These films show a T_c of 75–85 K. They have

discussed the importance of the reaction temperature, bath composition, water and oxygen contents of the bath, experimental conditions such as stirring (during electrodeposition), and the environment in obtaining reproducible results.

5.6. Use of Pulsed Potentials. Alternating current pulsing of the electrode in metal nitrate solutions improves the quality of the films. Therefore, pulse electrode potential (typically -1 to -4 V) has been used in the preparation of many systems.

Cathodic deposition of the precursor film for the YBaCuO system has been carried out from a mixed-metal nitrate bath containing KCN as well as a complexing agent. Cyanide bath⁸⁹ offers the advantage of a small range of electrode cycling potential, as the cyanide brings the reduction potential of Cu closer to that of Y and Ba. The superconductive films obtained from a cyanide bath show a T_c ~92 K which is greater than all other reported values for this class of superconductors, obtained by electrochemical techniques.

6. Electrosynthesis of Nanomaterials: Oxides, Oxysalts, and Composites

There are several motivations to synthesize nanoparticulate materials: (1) The band gap of a semiconductor can be tuned by limiting the particle size in the nanometer range. (2) Tunneling effects begin to predominate opening up possibilities of fabricating novel devices based on tunneling. Nanoparticulate materials—single-phase compounds as well as composites—for electronic applications are usually made by high-vacuum techniques. Devising electrosynthetic routes to such materials is an important challenge. Micrometer thick films of semiconducting Cu₂O have been electrodeposited from an alkaline cupric lactate bath by cathodic deposition within a well-defined potential (or current) window. Outside this window, initially, Cu/Cu₂O composites and later Cu deposition was observed.⁹⁰ When the deposition conditions were varied to obtain Cu/Cu₂O composites in the nanometer range, the band gap of Cu₂O was found to shift from the bulk value, 2.1 eV, to 2.5 eV together with a sharp increase in the absorption coefficient, as a result of quantum confinement effects.⁹¹ An interesting feature of the cathodic deposition of Cu/Cu₂O nanofilms is the oscillation of the cell potential during electrodeposition at constant current.⁹¹ These oscillations are attributed to the build up and break down of the highly resistive Cu₂O films. The resulting coating consists of alternate layers of Cu and Cu₂O and the modulation length can be directly measured using STM where conductivity variation between the layers affects the tunneling current to produce a striking contrast in the micrograph.⁹²

Compositionally nanomodulated layer-by-layer deposits in the Pb–Tl–O system have also been electrosynthesized (see section 4.3) by pulsed deposition^{93,94} and STM employed to probe the apparent corrugation of the deposit.

Another element of interest in the synthesis of nanoparticles, is morphology. For a number of applications it is desirable to have monodisperse particles having a predetermined orientation. Switzer and co-workers⁹⁵ have indeed succeeded in obtaining epitaxial deposits

of silver oxysalts on a prefabricated oxide substrate. Both X-ray diffraction and microscopic studies reveal the epitaxial faceting of the deposit.

7. Conclusions

In this review, we have surveyed emerging electrosynthetic routes to metal oxides and hydroxides. Our survey is illustrative rather than exhaustive in nature. The use of electrosynthesis in obtaining thin/thick films and coatings, metastable phases, and nanoparticulate morphology in a variety of oxides and hydroxides has been demonstrated. It is hoped that the simplicity and versatility of this technique will find it a permanent place in synthetic solid-state chemistry.

References

- (1) Longo, J. M.; Horowitz, H. S. In *Preparation and Characterization of Materials*; Rao, C. N. R., Honig, J., Ed.; Academic Press: New York, 1981; p 29.
- (2) (a) Rao, C. N. R.; Gopalakrishnan, J. *Acc. Chem. Res.* **1982**, *15*, 228. (b) Gopalakrishnan, J. *Proc. Ind. Acad. Sci. (Chem. Sci.)* **1984**, *93*, 421. (c) Gopalakrishnan, J.; Bhuvanesh, N. S. P.; Rangan, K. K. *Curr. Opin. Solid State Mater. Sci.* **1996**, *1*, 285. (d) Brinker, C. J.; Scherer, G. W. *Sol-Gel Science*; Academic Press: Boston, 1990. (e) Rabenau, A. *Angew. Chem.* **1985**, *24*, 1026. (f) Roy, R. *J. Solid State Chem.* **1994**, *111*, 11. (g) Treece, R. E.; Gillan, E. G.; Kaner, R. B. *Comments Inorg. Chem.* **1995**, *16*, 313. (h) Kriechbaum, G. W.; Kleinschmit, P. *Adv. Mater.* **1989**, *28*, 1416.
- (3) (a) Warren, J. L.; Geballe, T. H. *Mater. Sci. Eng.* **1981**, *50*, 149. (b) Rao, C. N. R. *Mater. Sci. Eng.* **1993**, *B18*, 1.
- (4) (a) Rüdorff, W.; Sick, H. H. *Angew. Chem.* **1959**, *71*, 127. (b) Rüdorff, W. *Angew. Chem.* **1959**, *71*, 487.
- (5) Rao, C. N. R.; Gopalakrishnan, J. *New directions in Solid State Chemistry*; Cambridge University Press: Cambridge, U.K., 1986; Chapter 3.
- (6) Rouxel, J.; Tournoux, M.; Brec, J. *Soft Chemistry Routes to New Materials*; Trans Tech Publications: Switzerland, 1993.
- (7) Gopalakrishnan, J. *Chem. Mater.* **1995**, *7*, 1265.
- (8) Figlarz, M. *Prog. Solid State Chem.* **1989**, *19*, 1.
- (9) Joint Meeting of the European Materials Research Society-Materials Research Society of India, JN Centre for Advanced Scientific Research, Bangalore, India; Dec. 8-14; 1996.
- (10) (a) Yugami, H.; Naito, H.; Arashi, H.; Ishigame, M. *Solid State Ionics* **1996**, *86*, 1307. (b) Liaw, B. Y.; Rocheleau, R. E.; Gao, Q.-H. *Solid State Ionics* **1996**, *92*, 85. (c) Byun, C.; Jang, J. W.; Kim, I. T.; Hong, K. S.; Lee, B.-W. *Mater. Res. Bull.* **1997**, *32*, 431. (d) Hartmanova, M.; Thurzo, I.; Jergel, M.; Bartos, J.; Kadlec, F.; Zelezny, V.; Tunega, D.; Kundracik, F.; Chromik, S.; Brunel, M. *J. Mater. Sci.* **1998**, *33*, 969. (e) Gao, Y.; Chambers, S. A. *Mater. Lett.* **1996**, *26*, 217.
- (11) Schöllhorn, R. *Angew. Chem.* **1980**, *19*, 983.
- (12) Wold, A.; Bellavance, D. In *Preparative Methods in Solid State Chemistry*; Hagenmuller, P., Ed.; Academic Press: New York, 1972; p 279.
- (13) Matsumoto, Y.; Morikawa, T.; Adachi, H.; Hombo, J. *Mater. Res. Bull.* **1992**, *27*, 1319.
- (14) Dobos, D. *Electrochemical Data*; Elsevier: New York, 1975.
- (15) (a) Jayashree, R. S.; Kamath, P. V. *J. Appl. Electrochem.* **1999**, *29*, 449. (b) Jayashree, R. S.; Kamath, P. V. *J. Mater. Chem.* **1999**, *9*, 961. (c) Dixit, M.; Kamath, P. V.; Kumar, V. G.; Munichandraiah, N.; Shukla, A. K. *J. Power Sources* **1996**, *63*, 167 and references therein.
- (16) Therese, G. H. A.; Kamath, P. V. *J. Appl. Electrochem.* **1998**, *28*, 539.
- (17) Kamath, P. V.; Therese, G. H. A.; Gopalakrishnan, J. *J. Solid State Chem.* **1997**, *128*, 38.
- (18) Indira, L.; Kamath, P. V. *J. Mater. Chem.* **1994**, *4*, 1487.
- (19) (a) Aries, L. *J. Appl. Electrochem.* **1994**, *24*, 554. (b) Aries, L.; Roy, J.; Sotoul, J.; Pontet, V.; Costeseque, P.; Algouy, T. *J. Appl. Electrochem.* **1996**, *26*, 617.
- (20) (a) Cavani, F.; Trifiro, F.; Vaccari, A. *Catal. Today* **1991**, *11*, 173. (b) Carrado, K. A.; Kostapapas, A.; Suib, S. L. *Solid State Ionics* **1988**, *26*, 77.
- (21) (a) Moneyron, J. E.; DeRoy, A.; Besse, J. P. *Sens. Actuators B* **1991**, *4*, 189. (b) Ookubo, A.; Ooi, K.; Hayashi, H. *Langmuir* **1993**, *9*, 1418. (c) Kamath, P. V.; Dixit, M.; Indira, L.; Shukla, A. K.; Munichandraiah, N.; Kumar, V. G. *J. Electrochem. Soc.* **1994**, *141*, 2956.
- (22) (a) Indira, L.; Dixit, M.; Kamath, P. V. *J. Power Sources* **1994**, *52*, 93. (b) Dixit, M.; Kamath, P. V. *J. Power Sources* **1995**, *56*, 97.
- (23) Switzer, J. A. *Am. Ceram. Soc. Bull.* **1987**, *66*, 1521.
- (24) Zhou, Y.; Phillips, R. J.; Switzer, J. A. *J. Am. Ceram. Soc.* **1995**, *78*, 981.
- (25) Li, F.-B.; Newman, R. C.; Thompson, G. E. *Electrochim. Acta* **1997**, *42*, 2455.
- (26) (a) Gal-Or, L.; Silberman, I.; Chaim, R. *J. Electrochem. Soc.* **1991**, *138*, 1939. (b) Chaim, R.; Silberman, I.; Gal-Or, L. *J. Electrochem. Soc.* **1991**, *138*, 1942. (c) Zhitomirsky, I.; Gal-Or, L.; Kohn, A.; Henniecke, H. W. *J. Mater. Sci.* **1995**, *30*, 5307. (d) Nakajima, K.; Shimada, S.; Inagaki, M. *J. Mater. Chem.* **1996**, *6*, 1795.
- (27) Natarajan, C.; Nogami, G. *J. Electrochem. Soc.* **1996**, *143*, 1547.
- (28) Zhitomirsky, I.; Gal-Or, L.; Klein, S. *J. Mater. Sci. Lett.* **1995**, *14*, 60.
- (29) Chaim, R.; Stark, G.; Gal-Or, L.; Bestgen, H. *J. Mater. Sci.* **1994**, *29*, 6241.
- (30) Chaim, R.; Stark, G.; Gal-Or, L.; Bestgen, H. *J. Mater. Sci. Lett.* **1994**, *13*, 487.
- (31) Chaim, R.; Zhitomirsky, I.; Gal-Or, L.; Bestgen, H. *J. Mater. Sci.* **1997**, *32*, 389.
- (32) Zhitomirsky, I.; Chaim, R.; Gal-Or, L.; Bestgen, H. *J. Mater. Sci.* **1997**, *32*, 5205.
- (33) Thanos, J. C. G.; Wabner, D. W. *J. Electroanal. Chem.* **1985**, *182*, 25.
- (34) Chaim, R.; Almaleh-Rockman, S.; Gal-Or, L. *J. Am. Ceram. Soc.* **1994**, *77*, 3202.
- (35) Lee, G. R.; Crayston, J. A. *J. Mater. Chem.* **1996**, *6*, 187.
- (36) (a) Izaki, M.; Omi, T. *J. Electrochem. Soc.* **1996**, *143*, L53. (b) Izaki, M.; Omi, T. *J. Electrochem. Soc.* **1997**, *144*, 1949. (c) Peulon, S.; Lincot, D. *Adv. Mater.* **1996**, *8*, 166.
- (37) (a) Yao, J. N.; Chen, P.; Fujishima, A. *J. Electroanal. Chem.* **1996**, *406*, 223. (b) Meulenkamp, E. A. *J. Electrochem. Soc.* **1997**, *144*, 1664. (c) Yao, J. N.; Chen, P.; Fujishima, A. *J. Electroanal. Chem.* **1996**, *406*, 223.
- (38) Baesa, R. R.; Rutsch, G.; Dougherty, J. P. *J. Mater. Res.* **1996**, *11*, 194.
- (39) (a) Zhitomirsky, I.; Kohn, A.; Gal-Or, L. *Mater. Lett.* **1996**, *25*, 223. (b) Matsumoto, Y.; Adachi, H.; Hombo, J. *J. Am. Ceram. Soc.* **1993**, *76*, 769. (c) Koinuma, M.; Ohmura, H.; Fujioka, Y.; Matsumoto, Y. *J. Solid State Chem.* **1998**, *136*, 293.
- (40) (a) Konno, H.; Tokita, M.; Furusaki, A.; Furuichi, R. *Electrochim. Acta* **1992**, *37*, 2421. (b) Konno, H.; Tokita, M.; Furuichi, R. *J. Electrochem. Soc.* **1990**, *137*, 361.
- (41) Matsumoto, Y.; Hombo, J. *J. Electroanal. Chem.* **1993**, *348*, 441.
- (42) Therese, G. H. A.; Kamath, P. V. *Mater. Res. Bull.* **1998**, *33*, 1.
- (43) Mercer, T.; De Groot, P. A. J.; Bartlett, P. N. *J. Appl. Electrochem.* **1998**, *28*, 455.
- (44) Therese, G. H. A.; Kamath, P. V. *Chem. Mater.* **1998**, *10*, 3364.
- (45) Therese, G. H. A.; Kamath, P. V.; Subbanna, G. N. *J. Mater. Chem.* **1998**, *8*, 405.
- (46) Shirkhazadeh, M. *J. Mater. Sci. Lett.* **1991**, *10*, 1415.
- (47) Monk, P. M. S.; Ali, T.; Partridge, R. D. *Solid State Ionics* **1995**, *80*, 75.
- (48) Janes, R.; Monk, P. M. S.; Partridge, R. D.; Hall, S. B. *J. Mater. Chem.* **1996**, *6*, 183.
- (49) (a) Streinz, C. C.; Hartman, A. P.; Motupally, S.; Weidner, J. W. *J. Electrochem. Soc.* **1995**, *142*, 1084. (b) Murthy, M.; Nagarajan, G. S.; Weidner, J. W.; Van Zee, J. W. *J. Electrochem. Soc.* **1996**, *143*, 2319.
- (50) Bullock, K. R. *J. Electroanal. Chem.* **1987**, *222*, 347.
- (51) Preisler, E. *J. Appl. Electrochem.* **1989**, *19*, 559.
- (52) Switzer, J. A. *J. Electrochem. Soc.* **1986**, *133*, 722.
- (53) Ismail, J. *A Study of the Electrosynthesis and Electrochemical behaviour of oxides/hydroxides of some first row Transition elements*; Bangalore University: Bangalore, 1994; Chapter 5.
- (54) Sakai, M.; Sekine, T.; Yamazaki, Y. *J. Electrochem. Soc.* **1983**, *130*, 1631.
- (55) Kuwabata, S.; Kishimoto, A.; Tanaka, T.; Yoneyama, H. *J. Electrochem. Soc.* **1994**, *141*, 10.
- (56) Tench, D.; Warren, L. F. *J. Electrochem. Soc.* **1983**, *130*, 869.
- (57) Andrukaitis, E.; Jacobs, P. W. M.; Lorimer, J. W. *Solid State Ionics* **1988**, *27*, 19.
- (58) Cho, W.-S.; Yoshimura, M. *J. Am. Ceram. Soc.* **1997**, *80*, 2199.
- (59) Cho, W.-S.; Yashima, M.; Kakihana, M.; Kudo, A.; Sakata, T.; Yoshimura, M. *J. Am. Ceram. Soc.* **1995**, *78*, 3110.
- (60) Yoshimura, M.; Ohmura, M.; Cho, W.-S.; Yashima, M.; Kakihana, M. *J. Am. Ceram. Soc.* **1997**, *80*, 2464.
- (61) (a) Sasaki, T.; Matsumoto, Y.; Hombo, J.; Ogawa, Y. *J. Solid State Chem.* **1991**, *91*, 61. (b) Sasaki, T.; Matsumoto, Y.; Hombo, J.; Nagata, M. *J. Electroanal. Chem.* **1994**, *371*, 241. (c) Matsumoto, Y.; Ohmura, H.; Goto, T. *J. Electroanal. Chem.* **1995**, *399*, 91. (d) Matsumoto, Y.; Sasaki, T.; Hombo, J. *Inorg. Chem.* **1992**, *31*, 738.
- (62) Matsumoto, Y.; Sasaki, T.; Hombo, J. *Electrochim. Acta* **1993**, *38*, 1145.
- (63) Hansen, H. C. B.; Koch, C. B. *Inorg. Chem.* **1994**, *33*, 5363.
- (64) Chen, Y.-W. D.; Noufi, R. N. *J. Electrochem. Soc.* **1984**, *131*, 1447.

- (65) Matsumoto, Y.; Hombo, J.; Qiong, C. *J. Electroanal. Chem.* **1990**, *279*, 331.
- (66) Monk, P. M. S.; Chester, S. L. *Electrochim. Acta.* **1993**, *38*, 1521.
- (67) (a) Kavan, L.; O'Regan, B.; Kay, A.; Grätzel, M. *J. Electroanal. Chem.* **1993**, *346*, 291. (b) Arsov, Lj. D.; Kormann, C.; Plieth, W. *J. Raman Spectrosc.* **1991**, *22*, 573.
- (68) Fouda, A. S. *J. Electroanal. Chem.* **1980**, *114*, 83.
- (69) Breyfogle, B. E.; Hung, C.-J.; Shumsky, M. G.; Switzer, J. A. *J. Electrochem. Soc.* **1996**, *143*, 2741.
- (70) Ismail, J.; Ahmed, M. F.; Kamath, P. V. *J. Power Sources* **1993**, *41*, 223; Dixit, M.; Therese, G. H. A.; Kamath, P. V. Unpublished Results.
- (71) Switzer, J. A.; Shane, M. J.; Phillips, R. J. *Science* **1990**, *247*, 444.
- (72) Bennett, J. C.; Oldert, M.; Scholz, G. A.; Boswell, F. W. *Phys. Rev. B* **1991**, *44*, 2727.
- (73) (a) Grenier, J.-C.; Wattiaux, A.; Laguey, N.; Park, J. C.; Marquestaut, E.; Etourneau, J.; Pouchard, M. *Physica C* **1991**, *173*, 139. (b) Radaelli, P. G.; Jorgensen, J. D.; Schultz, A. J.; Hunter, B. A.; Wagner, J. L.; Chou, F. C.; Johnston, D. C. *Phys. Rev. B* **1993**, *48*, 499. (c) Chou, F. C.; Johnston, D. C.; Cheong, S.-W.; Canfield, P. C. *Physica C* **1993**, *216*, 66. (d) Casañ-Pastor, N.; Gomez-Romero, P.; Fuertes, A.; Navarro, J. M.; Sanchis, M. J.; Ondoño, S. *Physica C* **1993**, *216*, 478. (e) Itoh, M.; Shan, Y.-J.; Sakamoto, S.; Inaguma, Y.; Nakamura, T. *Physica C* **1994**, *223*, 75.
- (74) Chou, F. C.; Cho, J. H.; Johnston, D. C. *Physica C* **1993**, *197*, 303.
- (75) Scholz, G. A.; Bennett, J. C.; Boswell, F. W. *Physica C* **1991**, *173*, 220.
- (76) Michel, C. R.; Casañ-Pastor, N. *Physica C* **1997**, *278*, 149.
- (77) Schwartz, M.; Cahen, D.; Rappaport, M.; Hodes, G. *Solid State Ionics* **1989**, *32/33*, 1137.
- (78) (a) Norten, M. *Mater. Res. Bull.* **1989**, *24*, 1391. (b) Marcus, J.; Escribe-Filippini, C.; Agarwal, S. K.; Chaillout, C.; Durr, J.; Fournier, T.; Tholence, J. L. *Solid State Commun.* **1991**, *78*, 967. (c) Zhao, L. Z.; Yin, B.; Zhang, J. B.; Li, J. W.; Xu, C. Y.; Liu, S. H.; Xie, M.; Li, Y.; Chen, X. A.; Chen, B. M. *Physica C* **1997**, *282-287*, 721. (d) Zhao, L. Z.; Yin, B.; Zhang, J. B.; Li, J. W.; Xu, C. Y. *Physica C* **1997**, *282-287*, 1311.
- (79) (a) Mosley, W. B.; Liu, J. Z.; Matsushita, A.; Lee, Y. P.; Klavins, P.; Shelton, R. N. *J. Crystal Growth* **1993**, *128*, 804. (b) Han, P. D.; Chang, L.; Payne, D. A. *J. Crystal Growth* **1993**, *128*, 798.
- (80) Tang, H. Y.; Lee, C. S.; Wu, M. K. *Physica C* **1994**, *231*, 325.
- (81) Zurawski, D. J.; Kulesza, P. J.; Wieckowski, A. *J. Electrochem. Soc.* **1988**, *135*, 1607.
- (82) Slezak, P.; Wieckowski, A. *J. Electrochem. Soc.* **1991**, *138*, 1038.
- (83) Monk, P. M. S.; Janes, R.; Partridge, R. D. *J. Mater. Chem.* **1998**, *8*, 1779.
- (84) Abolmaali, S. B.; Talbot, J. B. *J. Electrochem. Soc.* **1993**, *140*, 443.
- (85) (a) Bhattacharya, R. N.; Noufi, R.; Roybal, L. L.; Ahrenkiel, R. K. *J. Electrochem. Soc.* **1991**, *138*, 1643. (b) Weston, A.; Lalvani, S.; Willis, F.; Ali, N. *J. Alloys Compd.* **1992**, *181*, 233. (c) Bhattacharya, R. N.; Parilla, P. A.; Noufi, R.; Arendt, P.; Elliott, N. *J. Electrochem. Soc.* **1992**, *139*, 67. (d) Régner,.; Poissonnet, S.; Villars, G.; Louchet, C. *Physica C* **1997**, *282-287*, 2575.
- (86) Bhattacharya, R. N.; Duda, A.; Ginley, D. S.; DeLuca, J. A.; Ren, Z. F.; Wang, C. A.; Wang, J. H. *Physica C* **1994**, *229*, 145.
- (87) Maxfield, M.; Eckhardt, H.; Iqbal, Z.; Reidinger, F.; Baughman, R. H. *Appl. Phys. Lett.* **1989**, *54*, 1932.
- (88) Richardson, K. A.; Arrigan, D. M. W.; De Groot, P. A. J.; Lanchester, P. C.; Bartlett, P. N. *Electrochim. Acta* **1996**, *41*, 1629.
- (89) (a) Ondoño-Castillo, S.; Fuertes, A.; Pérez, F.; Gómez-Romero, P.; Casañ-Pastor, N. *Chem. Mater.* **1995**, *7*, 771. (b) Ondoño-Castillo, S.; Casañ-Pastor, N. *Physica C* **1997**, *276*, 251.
- (90) Golden, T. D.; Shumsky, M. G.; Zhou, Y.; VanderWerf, R. A.; Van Leeuwen, R. A.; Switzer, J. A. *Chem. Mater.* **1996**, *8*, 2499.
- (91) Switzer, J. A.; Hung, C.-J.; Bohannan, E. W.; Golden, T. D.; Van Aken, D. C. *Adv. Mater.* **1997**, *9*, 334.
- (92) Switzer, J. A.; Hung, C.-J.; Huang, L. Y.; Switzer, E. R.; Kammler, D. R.; Golden, T. D.; Bohannan, E. W. *J. Am. Chem. Soc.* **1998**, *120*, 3530.
- (93) Switzer, J. A.; Raffaele, R. P.; Phillips, R. J.; Hung, C.-J.; Golden, T. D. *Science* **1992**, *258*, 1918.
- (94) Phillips, R. J.; Golden, T. D.; Shumsky, M. G.; Bohannan, E. W.; Switzer, J. A. *Chem. Mater.* **1997**, *9*, 1670.
- (95) Breyfogle, B. E.; Phillips, R. J.; Switzer, J. A. *Chem. Mater.* **1992**, *4*, 1356.

CM990447A